

1MBI200S-120

IGBT Module

1200V / 200A 1 in one-package

■ Features

- High speed switching
- Voltage drive
- Low inductance module structure

■ Applications

- Inverter for Motor drive
- AC and DC Servo drive amplifier
- Uninterruptible power supply
- Industrial machines, such as Welding machines

■ Maximum ratings and characteristics

● Absolute maximum ratings (at Tc=25°C unless otherwise specified)

| Item | Symbol | Rating | Unit | | |
|---------------------------|------------------|-----------------------|----------------------|-----|---|
| Collector-Emitter voltage | V _{CEs} | 1200 | V | | |
| Gate-Emitter voltage | V _{GES} | ±20 | V | | |
| Collector current | Continuous | T _c =25°C | I _C | 300 | A |
| | | T _c =80°C | | 200 | A |
| | 1ms | T _c =25°C | I _C pulse | 600 | A |
| | | T _c =80°C | | 400 | A |
| | 1ms | | -I _c | 200 | A |
| | | -I _c pulse | 400 | A | |
| Max. power dissipation | P _c | 1500 | W | | |
| Operating temperature | T _j | +150 | °C | | |
| Storage temperature | T _{stg} | -40 to +125 | °C | | |
| Isolation voltage *1 | V _{is} | AC 2500 (1min.) | V | | |
| Screw torque | Mounting *2 | 3.5 | N·m | | |
| | Terminals *2 | 4.5 | N·m | | |
| | Terminals *2 | 1.7 | N·m | | |

*1 : All terminals should be connected together when isolation test will be done

*2 : Recommendable value : Mounting 2.5 to 3.5 N·m(M5 or M6)

Terminal 3.5 to 4.5 N·m(M6), 1.3 to 1.7N·m(M4)

● Electrical characteristics (at Tj=25°C unless otherwise specified)

| Item | Symbol | Characteristics | | | Conditions | Unit |
|--------------------------------------|----------------------|-----------------|-------|------|---|------|
| | | Min. | Typ. | Max. | | |
| Zero gate voltage collector current | I _{CEs} | – | – | 4.0 | V _{GE} =0V, V _{CE} =1200V | mA |
| Gate-Emitter leakage current | I _{GES} | – | – | 0.8 | V _{CE} =0V, V _{GE} =±20V | μA |
| Gate-Emitter threshold voltage | V _{GE(th)} | 5.5 | 7.2 | 8.5 | V _{CE} =20V, I _c =200mA | V |
| Collector-Emitter saturation voltage | V _{CE(sat)} | – | 2.3 | 2.6 | T _c =25° C, V _{GE} =15V, I _c =200A | V |
| | | – | 2.8 | – | T _c =125°C | |
| Input capacitance | C _{ies} | – | 24000 | – | V _{GE} =0V | pF |
| Output capacitance | C _{oes} | – | 5000 | – | V _{CE} =10V | |
| Reverse transfer capacitance | C _{res} | – | 4400 | – | f=1MHz | |
| Turn-on time | t _{on} | – | 0.35 | 1.2 | V _{CC} =600V I _c =200A V _{GE} =±15V R _G =4.7 ohm | μs |
| | t _r | – | 0.25 | 0.6 | | |
| | t _{r(i)} | – | 0.1 | – | | |
| Turn-off time | t _{off} | – | 0.45 | 1.0 | | |
| | t _f | – | 0.08 | – | | |
| Forward on voltage | V _F | – | 2.7 | 3.5 | T _j =25°C, I _F =200A, V _{GE} =0V | V |
| | | – | 2.4 | – | T _j =125°C | |
| Reverse recovery time | t _{rr} | – | – | 0.35 | I _F =200A | μs |

● Thermal resistance characteristics

| Item | Symbol | Characteristics | | | Conditions | Unit |
|--------------------|------------------------|-----------------|--------|-------|-------------------------|------|
| | | Min. | Typ. | Max. | | |
| Thermal resistance | R _{th(j-c)} | – | – | 0.085 | IGBT | °C/W |
| | R _{th(j-c)} | – | – | 0.22 | FWD | °C/W |
| | R _{th(c-f)*4} | – | 0.0125 | – | the base to cooling fin | °C/W |

*4 : This is the value which is defined mounting on the additional cooling fin with thermal compound



■ Equivalent Circuit Schematic

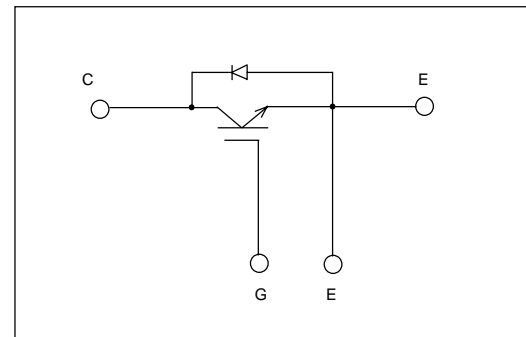

■ Characteristics

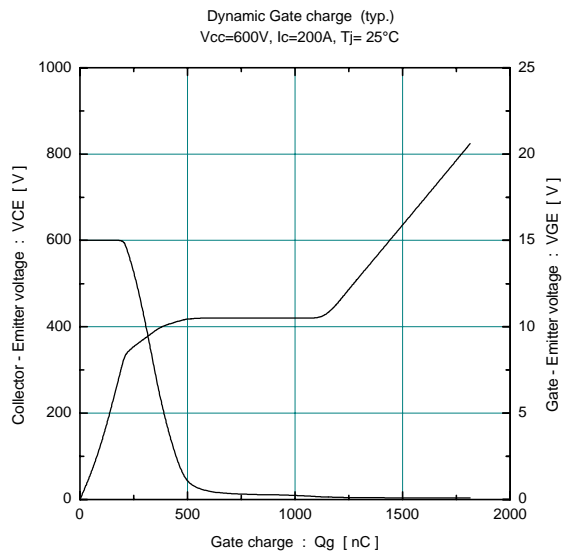
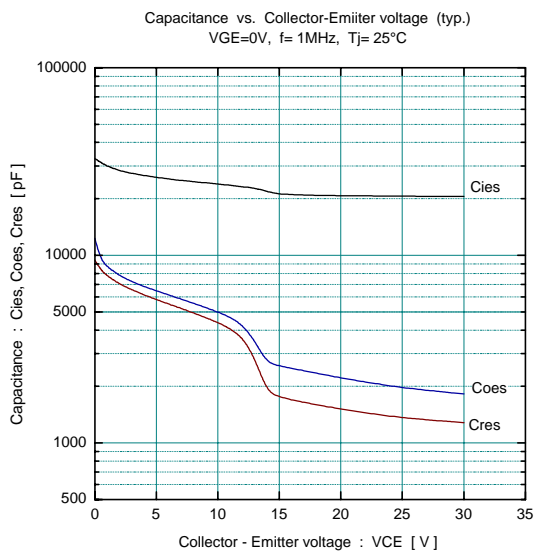
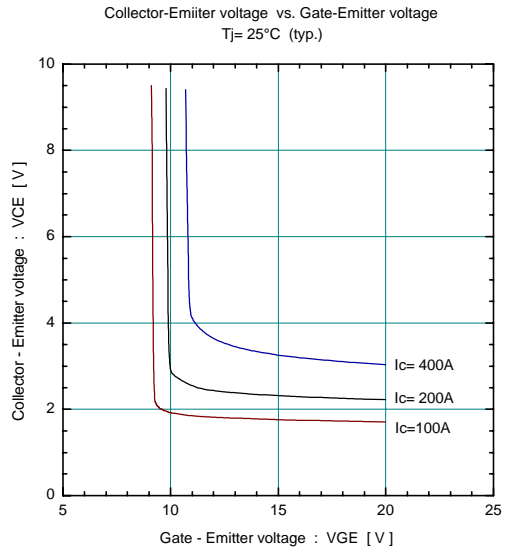
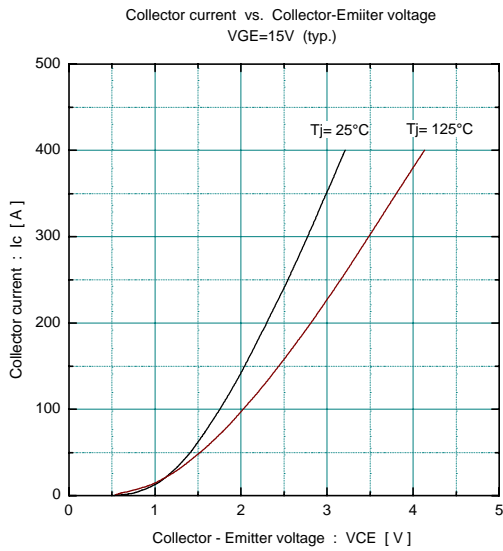
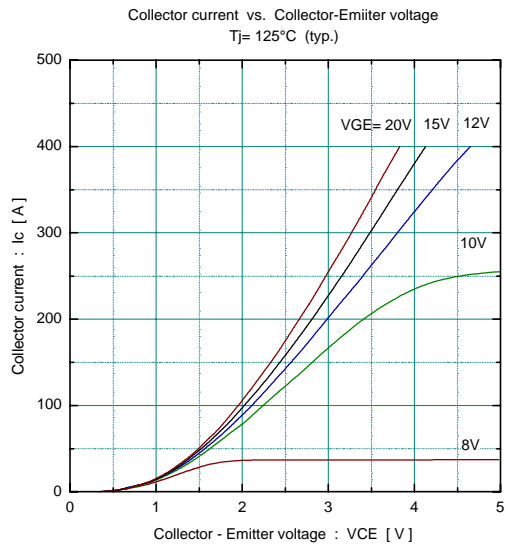
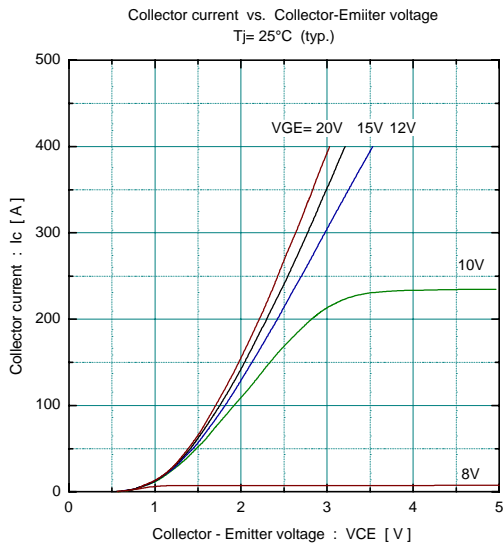

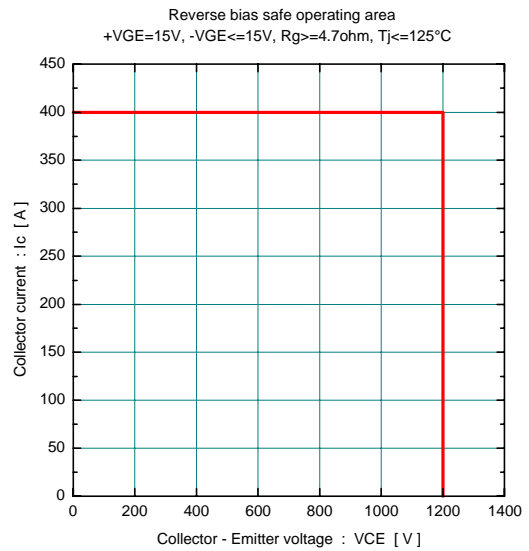
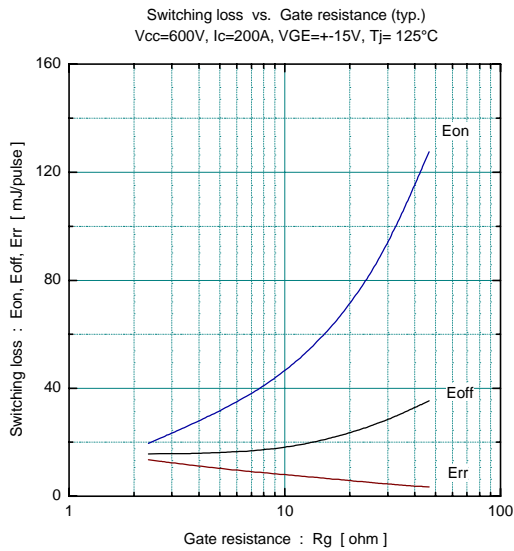
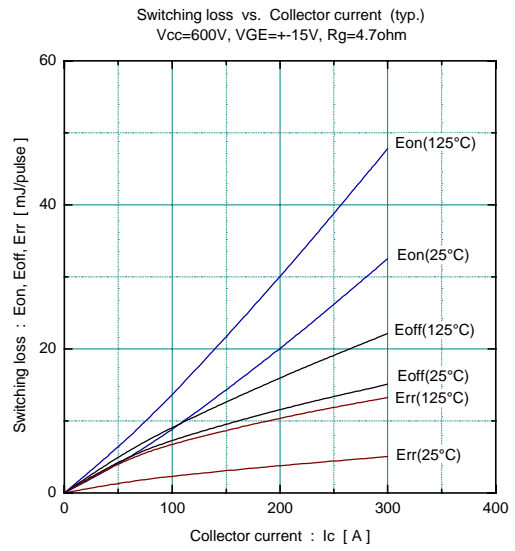
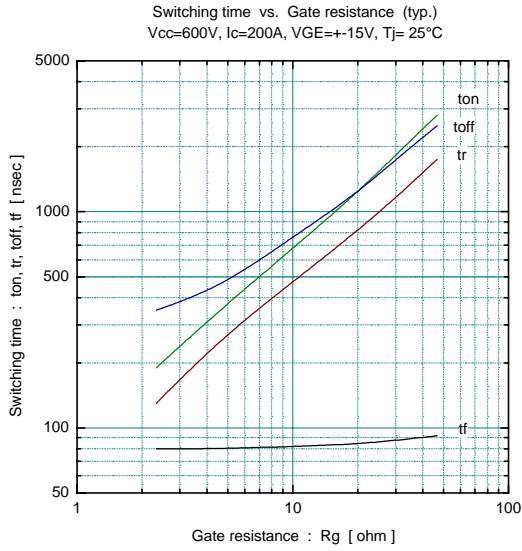
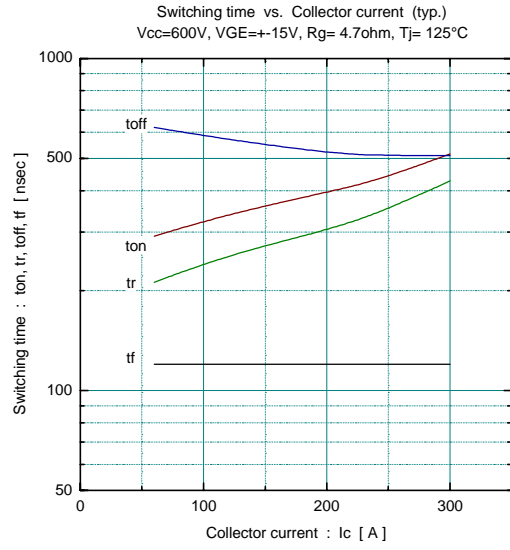
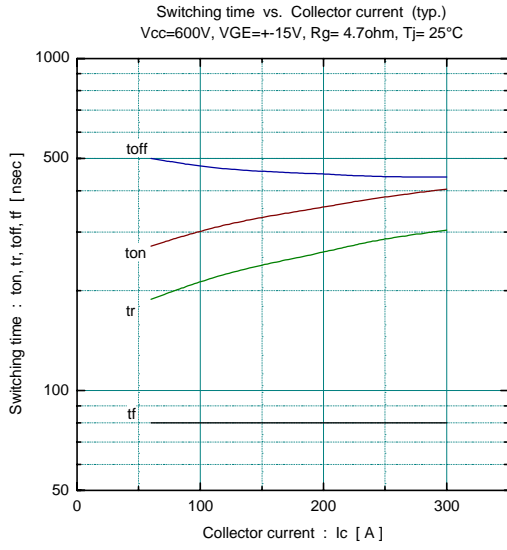

Forward current vs. Forward on voltage (typ.)

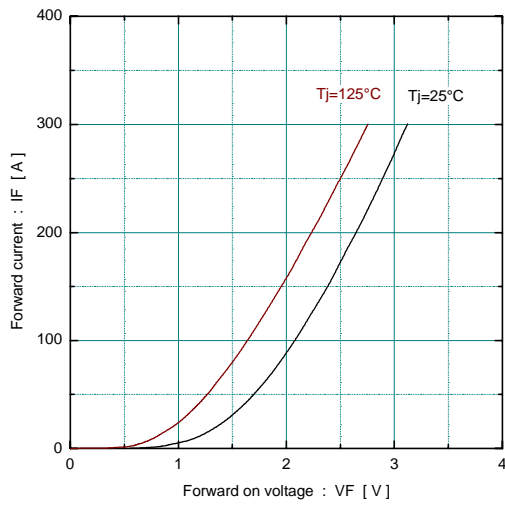

Reverse recovery characteristics (typ.)
Vcc=600V, VGE=+15V, Rg=4.7ohm

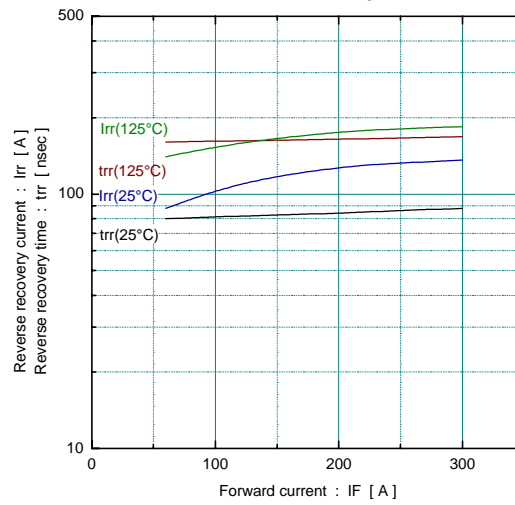

Transient thermal resistance

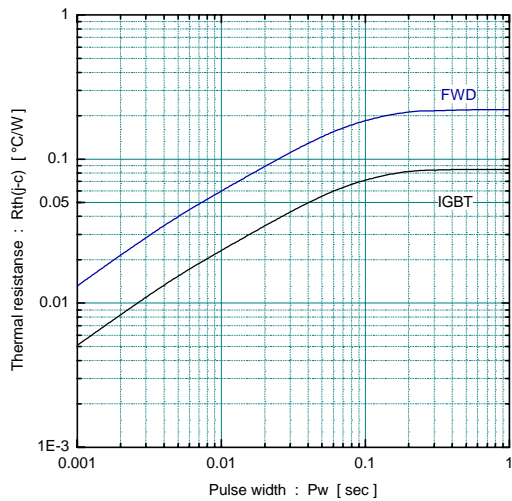

■ Outline Drawings, mm

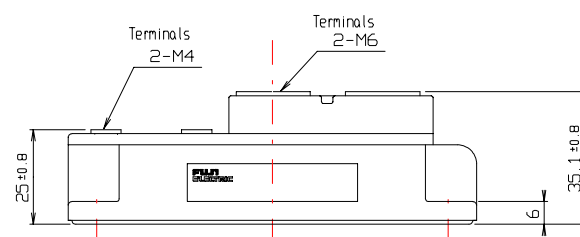
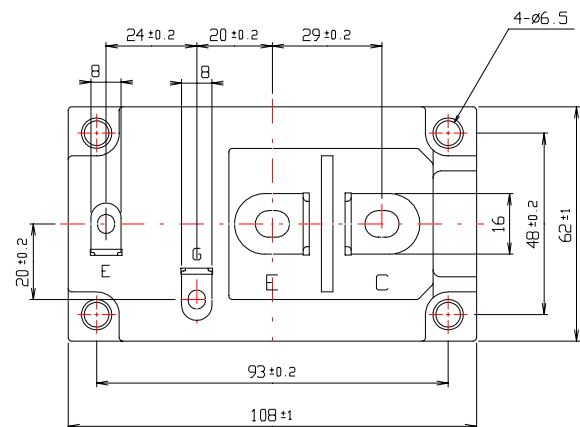

mass : 380g