



Data Sheet

ENMods™



Component Power Front-end System for EN Compliance

Features

- RoHS Compliant (with F or G pin style)
- Passive harmonic current attenuation to EN61000-3-2
- 575 W rated power output
- Autoranging 115/230 Vac input
- Inrush current limiting

Product Highlights

The ENMod system is a new AC front-end solution for compliance to electromagnetic compatibility (EMC) standards. It consists of the MiniHAM passive harmonic attenuation module and the FARM3 autoranging AC-DC front-end module. Combined with the filtering and hold-up capacitors as specified herein, the ENMod system provides full compliance to:

- EN61000-3-2 Harmonic Current
- EN55022, Level B Conducted Emissions
- EN61000-4-5 Surge Immunity
- EN61000-4-11 Line Disturbances
- EN61000-3-3 Inrush Current

The MiniHAM is the first passive product specifically designed for compliance to EN harmonic current limits. Unlike active PFC solutions, the MiniHAM generates no EMI, greatly simplifying and reducing system noise filtering requirements. It is also considerably smaller and more efficient than active alternatives and improves MTBF by an order of magnitude. Optimized for operation on the DC bus (provided by the FARM3) rather than directly on the AC line, it will provide harmonic current compliance at up to 600 W of input power at 230 Vac.

The 115/230 Vac input FARM3 is a new member of Vicor's filter and autoranging module product line that has been optimized for use as the front-end for the MiniHAM. Both modules are in Vicor's standard Mini half-brick package. Together with Vicor's 300 V input DC-DC converters, they form the basis of a low noise, high efficiency, rugged, simple and reliable EN compliant power system.



Each module:
2.28 x 2.2 x 0.5 in
57,9 x 55,9 x 12,7 mm

Absolute Maximum Ratings

Parameter	Rating	Unit	Notes
FARM3			
L to N voltage	264	V _{RMS}	Continuous
	280	V _{RMS}	100 ms
+Out to -Out voltage	400	Vdc	
BOK to -Out voltage	16	Vdc	
EN to -Out voltage	16	Vdc	
Mounting torque	4 – 6 (0.45 – 0.68)	in-lbs (N-m)	6 each, 4-40 screw
Operating temperature	-40 to +100	°C	H-Grade
Storage temperature	-55 to +125	°C	H-Grade
Pin soldering temperature	500 (260)	°F (°C)	<5 sec; wave solder
	750 (390)	°F (°C)	<7 sec; hand solder
Output current	3.5	A	
Baseplate temperature	100	°C	

Thermal Resistance

Parameter	Min	Typ	Max	Unit
Baseplate to sink				
flat, greased surface		0.16		°C/Watt
with thermal pad (P/N 20264)		0.14		°C/Watt
Baseplate to ambient				
Free convection		8.0		°C/Watt
1000 LFM		1.9		°C/Watt

Part Numbering

EN1	C	1	1
Product Type*	Product Grade Temperatures (°C)	Pin Style**	Baseplate
	Grade Operating Storage	1 = Short Pin 2 = Long Pin S = Short ModuMate N = Long ModuMate F = Short RoHS G = Long RoHS	1 = Slotted 2 = Threaded 3 = Thru-hole
	C = -20 to +100 -40 to +125 T = -40 to +100 -40 to +125 H = -40 to +100 -55 to +125		

*EN1 product includes one each MiniHAM and FARM3 with same product grade, pin and baseplate style.
**Pin styles S & N are compatible with the ModuMate interconnect system for socketing and surface mounting.

ELECTRICAL CHARACTERISTICS

Electrical characteristics apply over the full operating range of input voltage, output power and baseplate temperature, unless otherwise specified. All temperatures refer to the operating temperature at the center of the baseplate. Performance specifications are based on the ENMod system as shown in *Figure 1a*.

■ INPUT SPECIFICATIONS (see *Figure 3 thru Figure 7* for operating characteristics)

Parameter	Min	Typ	Max	Unit	Notes
Operating input voltage					
Low range	90	115	132	Vac	Autoranging (doubler mode)
High range	180	230	264	Vac	Autoranging (bridge mode)
Input undervoltage			90	Vac	Shutdown
AC line frequency	47		63	Hz	C-, and T-Grade
Power factor	0.68	0.72			Typical line
Inrush current			30	Amps	264 Vac line voltage

■ OUTPUT SPECIFICATIONS

Parameter	Min	Typ	Max	Unit	Notes
Output power	0		575	Watts	
Efficiency					
@ 115 Vac	93	94		%	Full load
@ 230 Vac	96	97		%	Full load
Output voltage	250		375	Vdc	
External hold-up capacitance			1,750	μF	2-3300 μF in Series-HUB 3300S

■ CONTROL SPECIFICATIONS

Parameter	Min	Typ	Max	Unit	Notes
AC Bus OK (BOK)					
Low state resistance			15	Ω	To negative output – Bus normal
Low state voltage			0.1	Vdc	50 mA maximum
High state voltage	14.8	15.0	15.2	Vdc	Bus abnormal, 27 k internal pull up to 15 Vdc (see <i>Fig. 12</i>)
BOK true threshold	235	240	245	Vdc	Output Bus voltage
BOK false threshold	200	205	210	Vdc	Output Bus voltage
Module Enable (EN)					
Low state resistance			15	Ω	To negative output – Converters disabled
Low state voltage			0.1	Vdc	50 mA maximum
High state voltage	14.8	15.0	15.2	Vdc	150 k internal pull up to 15 Vdc (see <i>Figure 11</i>)
Enable threshold	235	240		Vdc	Output bus voltage
Disable threshold	185	190	195	Vdc	Output bus voltage
AC Bus OK - Module Enable, differential error*	15	17	20	Vdc	AC Bus OK and Module Enable thresholds track

*Tracking error between BUS OK and Enable thresholds

■ ELECTROMAGNETIC COMPATIBILITY (configured as illustrated in *Figures 1a and 1b*)

Parameter	Standard	Notes
Harmonic currents	EN61000-3-2, Amendment 14	50 – 625 W, 230 Vac input 575 W output (see <i>Figure 2</i>)
Line disturbance / immunity	EN61000-4-11	Interruptions and brownouts
Transient / surge immunity	EN61000-4-5	2 kV – 50 μs line or neutral to earth 1 kV – 50 μs line to neutral
Conducted emissions	EN55022, Level B	With filter (see <i>Figures 1a and 1b</i>)
Flicker / inrush	EN61000-3-3	

ELECTRICAL CHARACTERISTICS (CONT.)

■ SAFETY SPECIFICATIONS (with baseplate earthed and quick acting line fuse 10 A max.)

Parameter	Min	Typ	Max	Unit	Notes
Isolation (in to out)		None			Isolation provided by DC-DC converter(s)
Dielectric withstand (I/O to baseplate)	2,121			Vdc	Baseplate earthed
Leakage current			2.5	mA	264 Vac

■ AGENCY APPROVALS

Safety Standards	Agency Markings	Notes
FARM3 EN60950, UL60950, CSA 60950	cTÜVus CE Marked	See License Conditions on the safety certificate Low voltage directive
MiniHAM EN60950, UL60950, CSA 60950	cTÜVus CE Marked	See License Conditions on the safety certificate Low voltage directive

■ GENERAL SPECIFICATIONS

Parameter	Min	Typ	Max	Unit	Notes
Baseplate material					Aluminum
MiniHAM cover					Dupont Zenite / Aluminum
FARM3 cover					Polyetherimide
Pin material					
Style 1 & 2					Copper, Tin/Lead solder plating
Style S & N (ModuMate compatible), Style F & G (RoHS compliant)					Copper, Nickel/Gold plating
Weight					
FARM3		3.1 (88)		Ounces (grams)	
MiniHAM		5.1 (145)		Ounces (grams)	
Size		2.25 x 2.2 x 0.5		Inches	Vicor's standard mini half-brick package
		57,9 x 55,9 x 12,7		mm	
MTBF		>1,000,000		Hours	25°C, Ground Benign MIL HDBK 217F

OPERATING CHARACTERISTICS

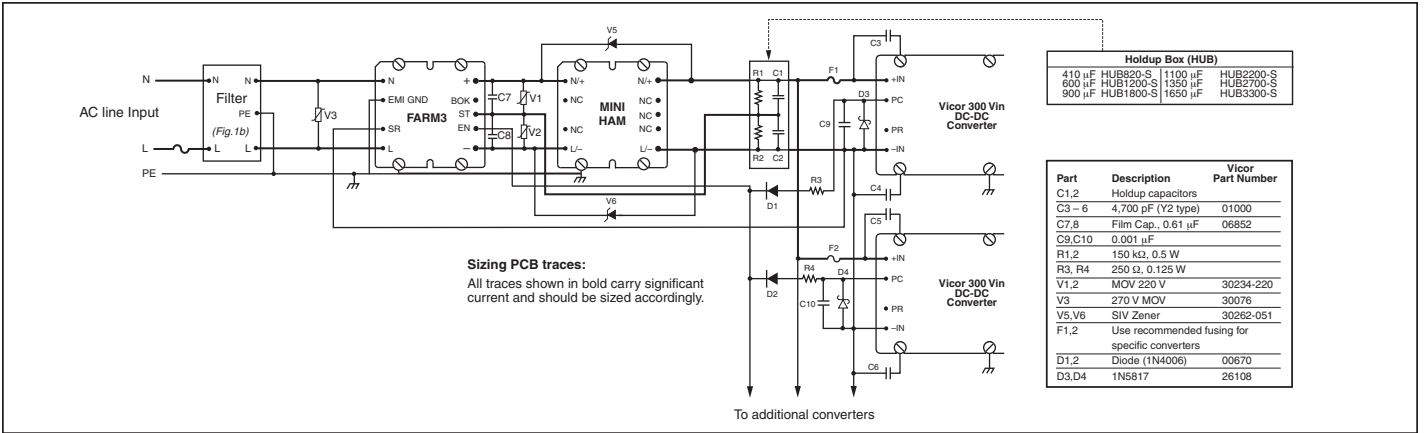

Figure 1a — Offline Power Supply Configuration

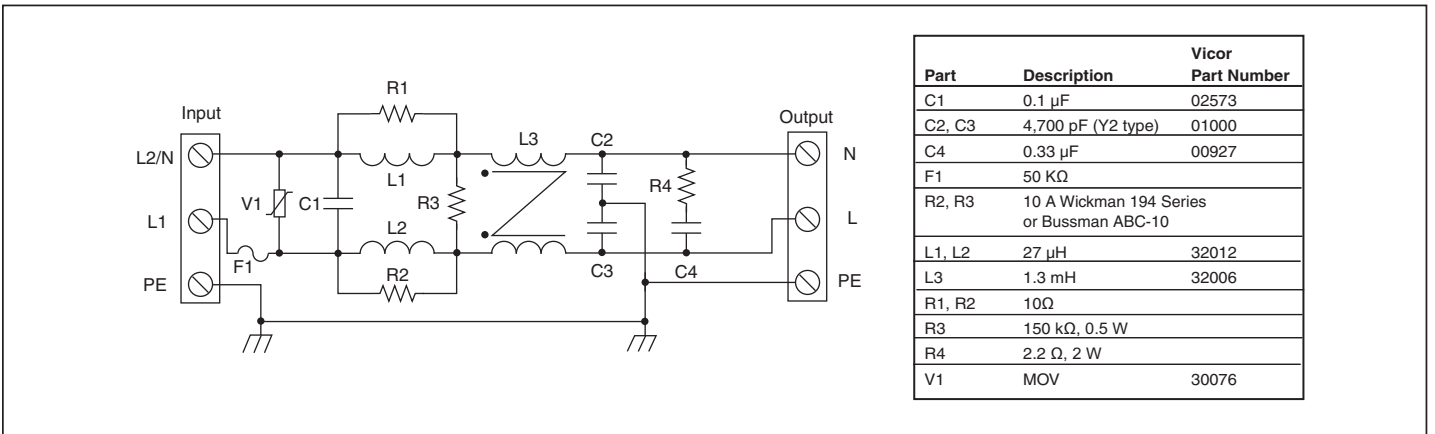

Figure 1b — Input EMI filter for EN55022, Level B compliance

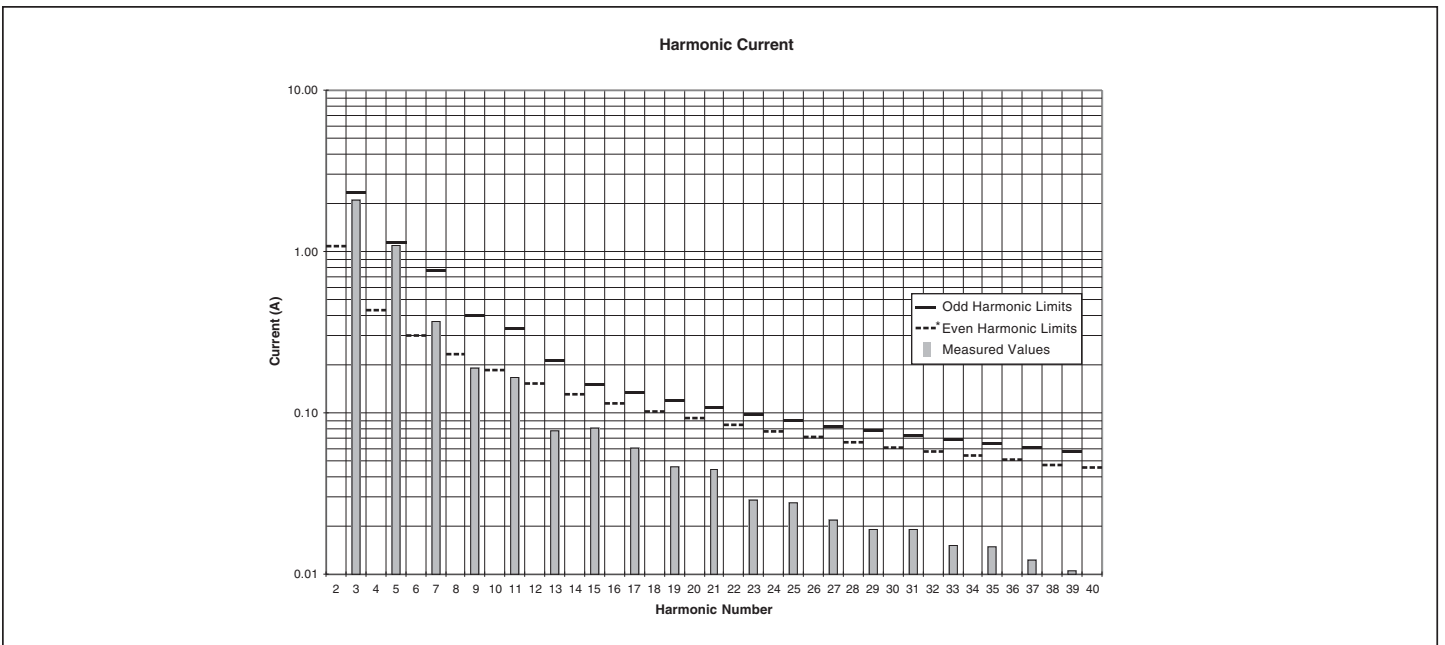

Figure 2 — Measured harmonic current at 230 Vac, 575 W vs. EN spec limits

*Measured values of even harmonics are below 0.01A

OPERATING CHARACTERISTICS (FARM3)

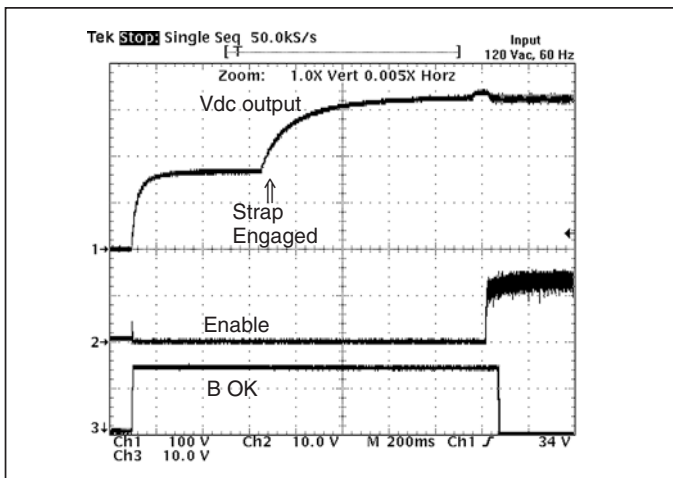

Figure 3 — Start-up at 120 Vac input

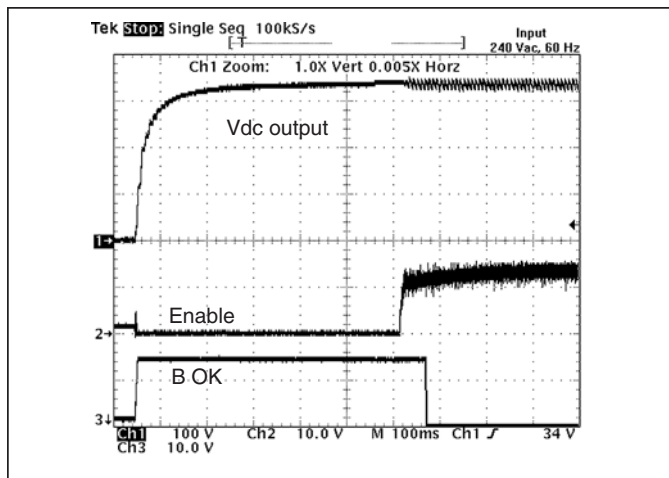

Figure 4 — Start-up at 240 Vac input

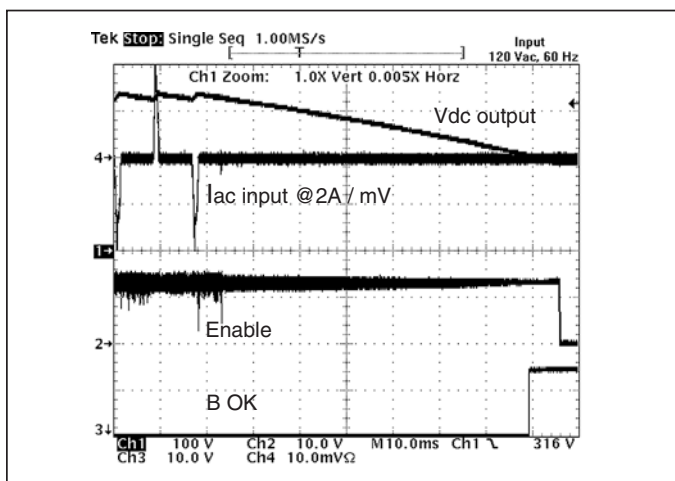

Figure 5 — Power-down from 120 Vac

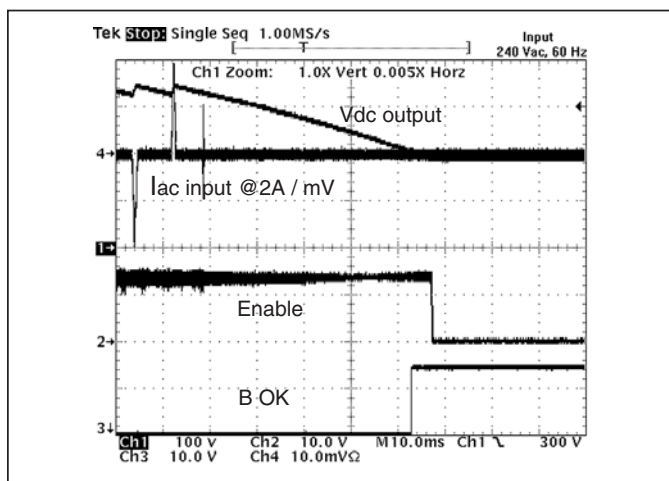

Figure 6 — Power-down from 240 Vac

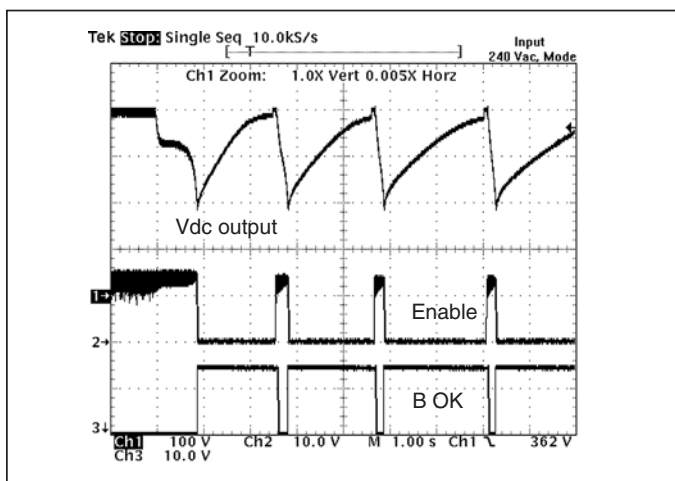

Figure 7 — Output overvoltage protection 240 Vac range

TYPICAL CONDUCTED EMISSIONS WITH V300 SERIES CONVERTER AND FILTER

(see Figure 1b)

Quasi Peak and Average Limits
230 V Input, 575 W Output

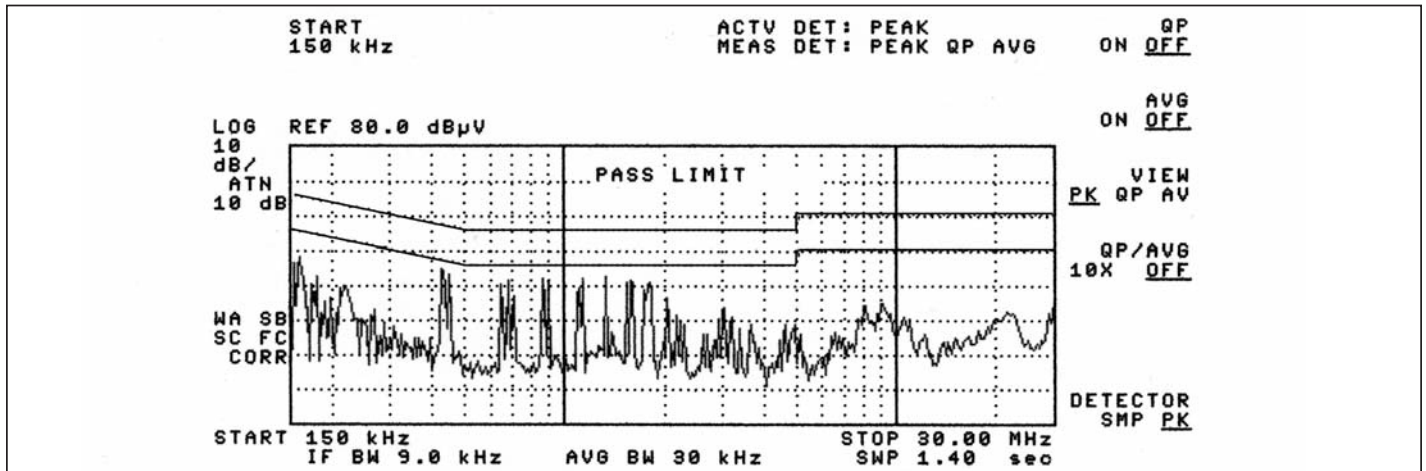

Figure 8a — Peak detection

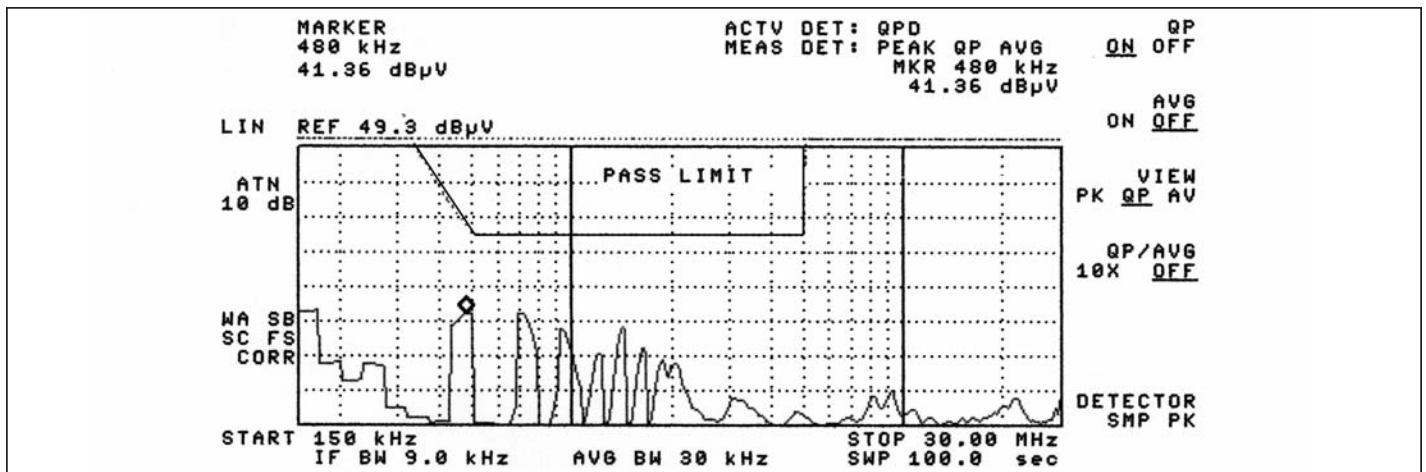

Figure 8b — Quasi peak detection

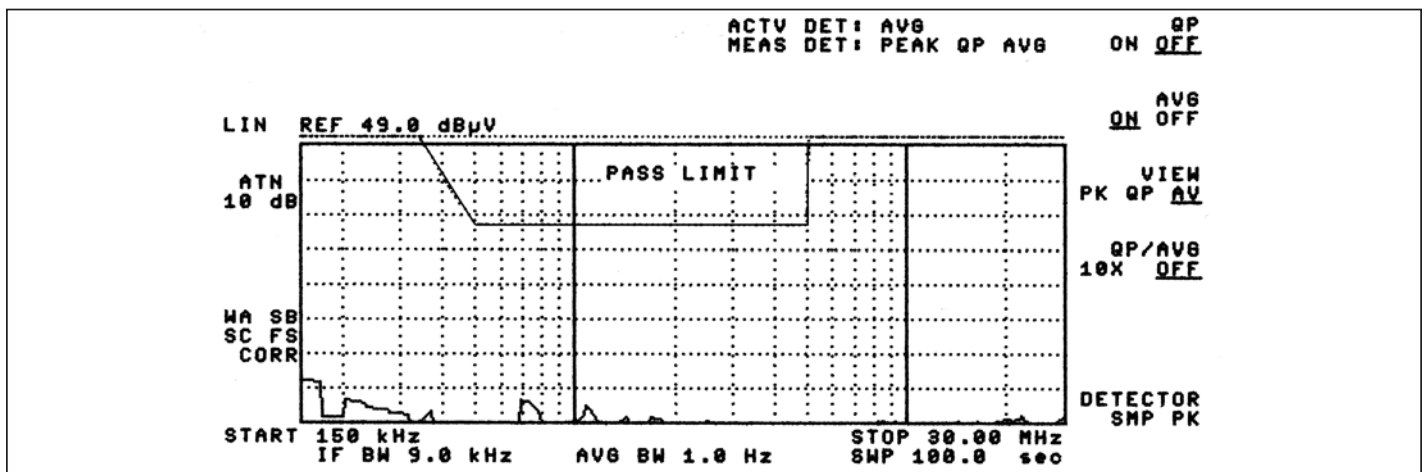

Figure 8c — Average detection

APPLICATION NOTE

The ENMod component power front-end system for EN compliance provides an effective solution for an AC front end of a power supply enabled with Vicor DC-DC converters. The ENMod system's basic building blocks are the MiniHAM passive harmonic attenuation module, the FARM3 autoranging AC-DC front-end module (Figure 9) and a discrete EMI filter.

The ENMod system provides transient/surge immunity, harmonic current attenuation and EMI filtering, in addition to all of the power switching and control circuitry necessary for autoranging rectification, inrush current limiting, and overvoltage protection. Converter enable and status functions for orderly power up/down control or sequencing are also provided. To complete the AC front-end configuration, the user only needs to add hold-up capacitors, a simple EMI filter, and a few discrete components (see Fig. 1a).

Functional Description (FARM3, see Figures 9 & 10)

Power-Up Sequence.

- 1.1** Upon application of input power, the hold-up capacitors begin to charge. The thermistor limits the charge current, and the exponential time constant is determined by the hold-up capacitor value and the thermistor cold resistance. The slope (dV/dt) of the capacitor voltage versus time approaches zero as the capacitors become charged to the peak of the AC line voltage.

The switch that bypasses the inrush limiting PTC (positive temperature coefficient) thermistor is open when power is applied, as is the switch that engages the strap for voltage doubling. In addition, the converter modules are disabled via the Enable (EN) line, and Bus-OK (BOK) is high.

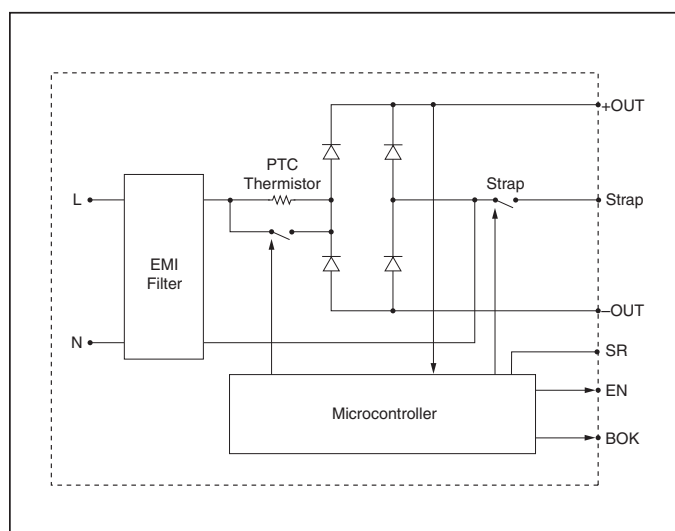

Figure 9 — Functional block diagram: FARM3 module

- 2.1** If the bus voltage is less than 200 V as the slope nears zero, the voltage doubler is activated, and the bus voltage climbs exponentially to twice the peak line voltage. If the bus voltage is greater than 200 V, the doubler is not activated.
- 3.1** If the bus voltage is greater than 235 V as the slope approaches zero, the inrush limiting thermistor is bypassed. Below 235 V, it is not bypassed.
- 4.1** The converters are enabled 50 milliseconds after the thermistor bypass switch is closed.
- 5.1** Bus-OK is asserted after an additional 50 millisecond delay to allow the converter outputs to settle within specification.

Power-Down Sequence. When input power is turned off or fails, the following sequence occurs as the bus voltage decays:

- 1.2** Bus-OK is deasserted when the bus voltage falls below 210 Vdc.
- 2.2** The converters are disabled when the bus voltage falls below 190 Vdc. If power is reapplied after the converters are disabled, the entire power-up sequence is repeated. If a momentary power interruption occurs and power is reestablished before the bus reaches the disable threshold, the power-up sequence is not repeated, i.e., the power conversion system “rides through” the momentary interruption.

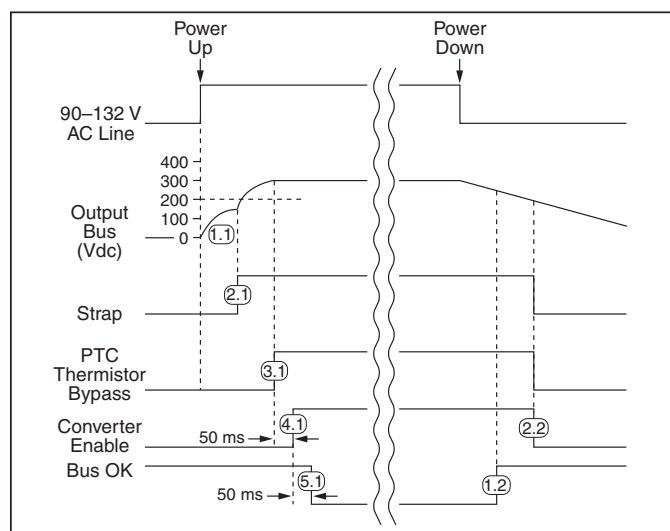

Figure 10 — Timing diagram: power-up/down sequence

APPLICATION NOTE (CONT.)

Off-Line Power Supply Configuration

The ENMod system maintains the DC output bus voltage between 250 and 370 Vdc over the entire input voltage range, which is compatible with all Vicor 300 V input converters. Autoranging automatically switches to the proper bridge or doubler mode at startup depending on the input voltage, eliminating the possibility of damage due to improper line connection. The ENMod system is rated at 575 W output power. These modules can serve as the AC front-end for any number and combination of compatible converters as long as the maximum power rating is not exceeded.

FARM3 Module Pin Descriptions

(see Figures 1a, 18a and 18b)

Strap (ST) Pin. In addition to input and output power pin connections, it is necessary to connect the Strap pin to the center junction of the series hold-up capacitors (C1, C2) for proper (autoranging) operation. Varistors V1 and V2 provide capacitor protection. The bleeder resistors (R1, R2) discharge the hold-up capacitors when power is switched off. Capacitors C7 and C8 are recommended if the hold-up capacitors are located more than 3 inches (75mm) from the output pins.

Enable (EN) Pin. The Enable pin must be connected to the PC or Gate-In pin of all converter modules to disable the converters during power-up. Otherwise, the converters would attempt to start while the hold-up capacitors are being charged through the current limiting thermistor, preventing the bus voltage from reaching the thermistor bypass threshold, thus disabling the power supply. The Enable output (the drain of an N channel MOSFET) is internally pulled up to 15 V through a 150 k Ω resistor. (see Figure 11)

A signal diode should be placed close to and in series with the PC or (Gate-In) pin of each converter to eliminate the possibility of control interference between converters. The Enable pin switches to the high state (15 V) with respect to the SR pin to turn on the converters after the power-up inrush is over. The Enable function also provides input overvoltage protection for the converters by turning off the converters if the DC bus voltage exceeds 400 Vdc. The thermistor bypass switch opens if this condition occurs, placing the thermistor in series with the input voltage, reducing the bus voltage to a safe level while limiting input current in case the varistors conduct. The thermistor bypass switch also opens if a fault or overload reduces the bus voltage to less than 180 Vdc. (see Figure 9)

CAUTION: There is no input to output isolation in the ENMods, hence the –Out of the ENMods and thus the –In of the downstream DC-DC converter(s) are at a high potential. If it is necessary to provide an external enable / disable function by controlling the DC-DC converter's PC pin (referenced to the –In) of the converter an opto-isolator or isolated relay should be employed.

Bus-OK (BOK) Pin. (see Figure 12) The Bus-OK pin is intended to provide early-warning power fail information and

is also referenced to the SR pin.

CAUTION: There is no input to output isolation in the ENMods. It is necessary to monitor Bus-OK via an optoisolator if it is to be used on the secondary (output) side of the converters. A line isolation transformer should be used when performing scope measurements. Scope probes should never be applied simultaneously to the input and output as this will destroy the unit.

L, N Pins. Line and neutral input.

+, – Pins. Positive and negative outputs.

SR Pin. Signal return for BOK and EN outputs.

MiniHAM Module Pin

(see Figures 1a, 18a, and 18b)

Filter (see Figure 1b)

The input EMI filter consists of differential and common mode chokes, Y– rated capacitors (line-ground) and X– rated capacitors (line-line). This filter configuration provides sufficient common mode and differential mode insertion loss in the frequency range between 100 kHz and 30 MHz to comply with the Level B conducted emissions limit, as illustrated in Figures 8a thru 8c.

APPLICATION NOTE (CONT.)

Hold-up Capacitors

Hold-up capacitor values should be determined according to output bus voltage ripple, power fail hold-up time, and ride-through time (see Figure 15). Many applications require the power supply to maintain output regulation during a momentary power failure of specified duration, i.e., the converters must hold-up or ride through such an event while maintaining undisturbed output voltage regulation. Similarly, many of these same systems require notification of an impending power failure in order to allow time to perform an orderly shutdown.

The energy stored on a capacitor which has been charged to voltage V is:

$$\mathcal{E} = 1/2(CV^2) \quad (1)$$

Where: \mathcal{E} = stored energy
 C = capacitance
 V = voltage across the capacitor

Energy is given up by the capacitors as they are discharged by the converters. The energy expended (the power-time product) is:

$$\mathcal{E} = P\Delta t = C(V_1^2 - V_2^2) / 2 \quad (2)$$

Where: P = operating power
 Δt = discharge interval
 V_1 = capacitor voltage at the beginning of Δt
 V_2 = capacitor voltage at the end of Δt

Rearranging Equation 2 to solve for the required capacitance:

$$C = 2P\Delta t / (V_1^2 - V_2^2) \quad (3)$$

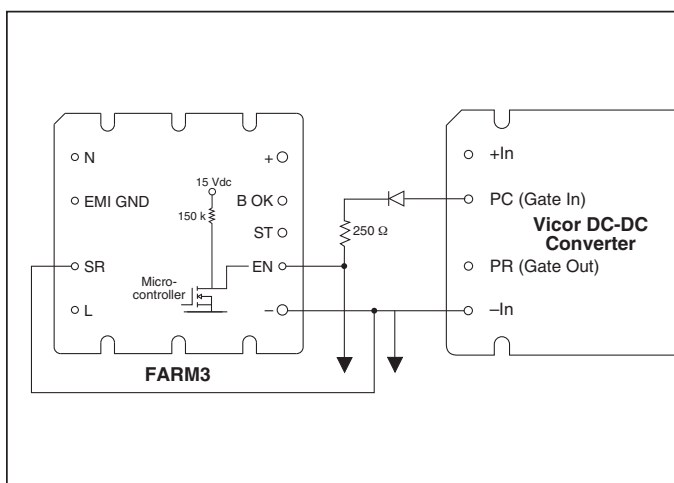

Figure 11 — Enable (EN) function

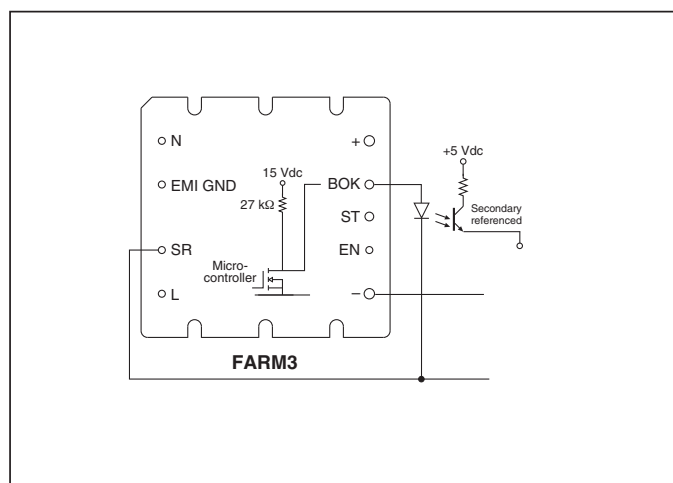

Figure 12 — Bus OK (BOK) isolated power status indicator

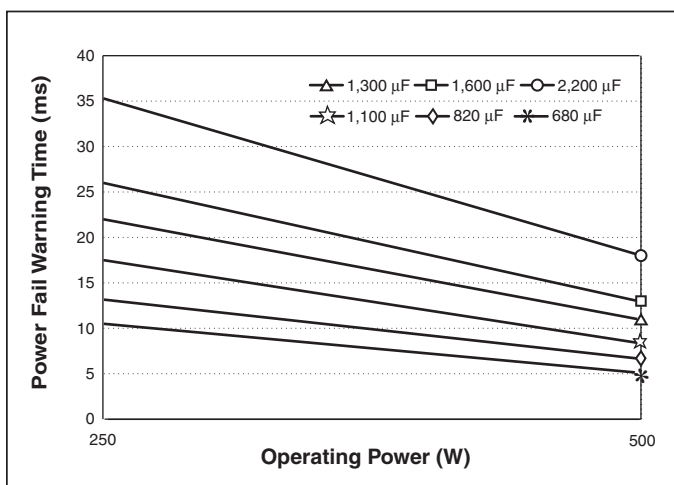

Figure 13 — Power fail warning time vs. operating power and total bus capacitance, series combination of $C1$, $C2$ (see Figure 1a)

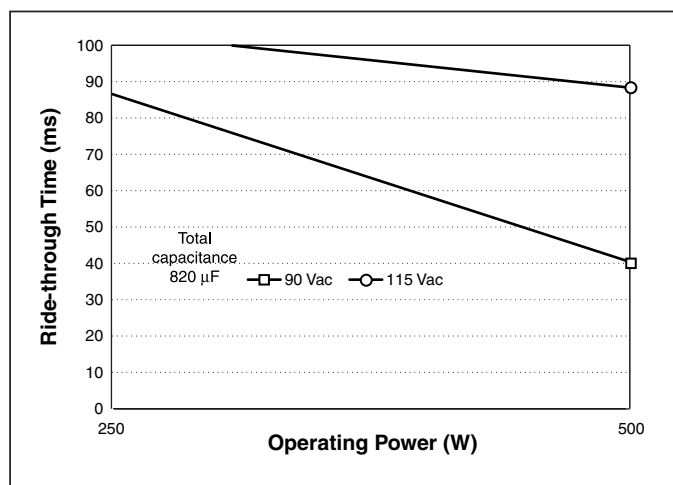

Figure 14 — Ride-through time vs. operating power

APPLICATION NOTE (CONT.)

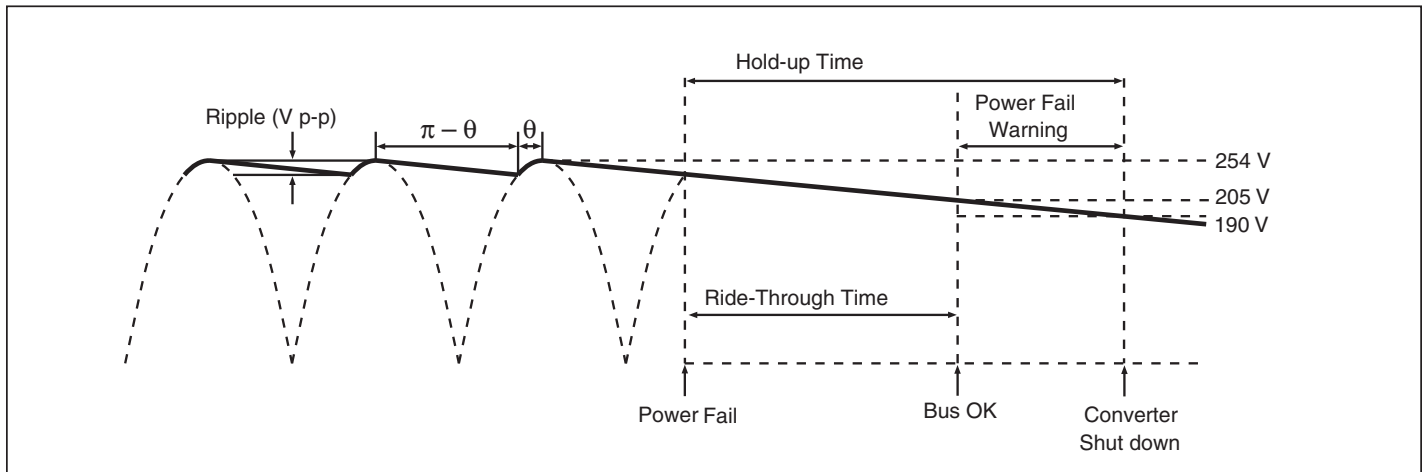

Figure 15 — Hold-up time

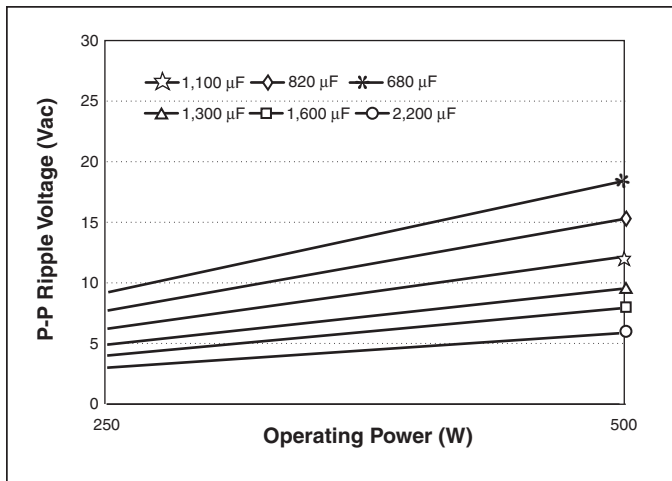

Figure 16 — Ripple voltage vs. operating power and bus capacitance, series combination of C1, C2 (see Figure 1a)

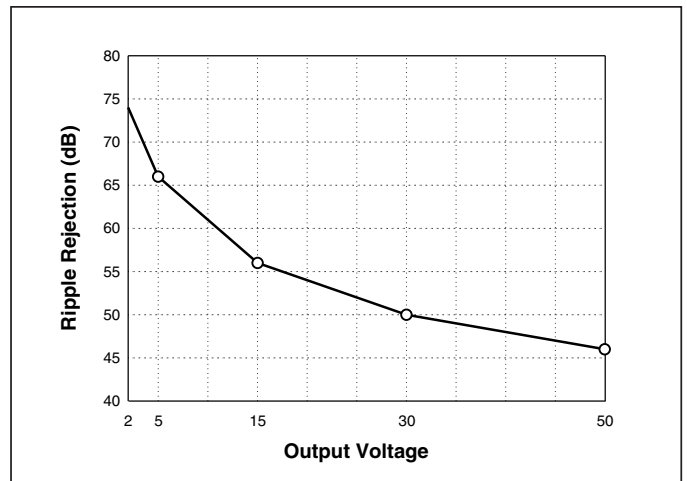

Figure 17 — Converter ripple rejection vs. output voltage

APPLICATION NOTE (CONT.)

The power fail warning time (Δt) is defined as the interval between BOK and converter shutdown (EN) as illustrated in *Figure 15*. The Bus-OK and Enable thresholds are 205 V and 190 V, respectively. A simplified relationship between power fail warning time, operating power, and bus capacitance is obtained by inserting these constants in Equation (3):

$$C = 2P\Delta t / (205^2 - 190^2)$$
$$C = 2P\Delta t / (5,925)$$

It should be noted that the series combination ($C1$, $C2$, see *Figure 1a*) requires each capacitor to be twice the calculated value, but the required voltage rating of each capacitor is reduced to 200 V.

Allowable ripple voltage on the bus (or ripple current in the capacitors) may define the capacitance requirement. Consideration should be given to converter ripple rejection.

Equation 3 is again used to determine the required capacitance. In this case, V_1 and V_2 are the instantaneous values of bus voltage at the peaks and valleys (see *Figure 15*) of the ripple, respectively. The capacitors must hold up the bus voltage for the time interval (Δt) between peaks of the rectified line as given by:

$$\Delta t = (\pi - \theta) / 4\pi f \quad (5)$$

Where: f = line frequency
 θ = rectifier conduction angle

The approximate conduction angle is given by:

$$\theta = \cos^{-1}(V_2/V_1) \quad (6)$$

Another consideration in hold-up capacitor selection is their ripple current rating. The capacitors' rating must be higher than the maximum operating ripple current. The approximate operating ripple current (rms) is given by:

$$I_{rms} = 2P/V_{ac} \quad (7)$$

Where: P = total output power
 V_{ac} = operating line voltage

Calculated values of bus capacitance for various hold-up time, ride-through time, and ripple voltage requirements are given as a function of operating power level in *Figures 13, 14, and 16*, respectively.

Example

In this example, the output required from the DC-DC converter at the point of load is 12 Vdc at 320 W. Therefore, the output power from the ENMods would be 375 W (assuming a converter efficiency of 85%). The desired hold-up time is 9 ms over an input range of 90 to 264 Vac.

Determining Required Capacitance for Power Fail

Warning. *Figure 13* is used to determine capacitance for a given power fail warning time and power level, and shows that the total bus capacitance should be at least 820 μ F. Since two capacitors are used in series, each capacitor should be at least 1,640 μ F. Note that warning time is not dependent on line voltage. A hold-up capacitor calculator is available on the Vicor website, at vicorpower.com/hubcalc.

Determining Ride-through Time. *Figure 14* illustrates ride-through time as a function of line voltage and output power, and shows that at a nominal line of 90 Vac, ride-through would be 68 ms. Ride-through time is a function of line voltage.

Determining Ripple Voltage on the Hold-up Capacitors.

Figure 16 is used to determine ripple voltage as a function of operating power and bus capacitance, and shows that the ripple voltage across the hold-up capacitors will be 12 Vp-p.

Determining the Ripple on the Output of the DC-DC Converter. *Figure 17* is used to determine the ripple rejection of the DC-DC converter and indicates a ripple rejection of approximately 60 dB for a 12 V output. Since the ripple on the bus voltage is 12 Vac and the ripple rejection of the converter is 60 dB, the output ripple of the converter due to ripple on its input (primarily 120 Hz) will be 12 mVp-p.

A variety of hold-up capacitor assemblies (HUBs) are available. Please visit the Vicor website at vicorpower.com/hub.

For more information about designing an autoranging AC input power supply using the ENMods and Vicor DC-DC converter modules, contact Vicor Applications Engineering at the nearest Vicor Technical Support Center, or send E-mail to apps@vicorpower.com.

• • •

MECHANICAL DRAWINGS

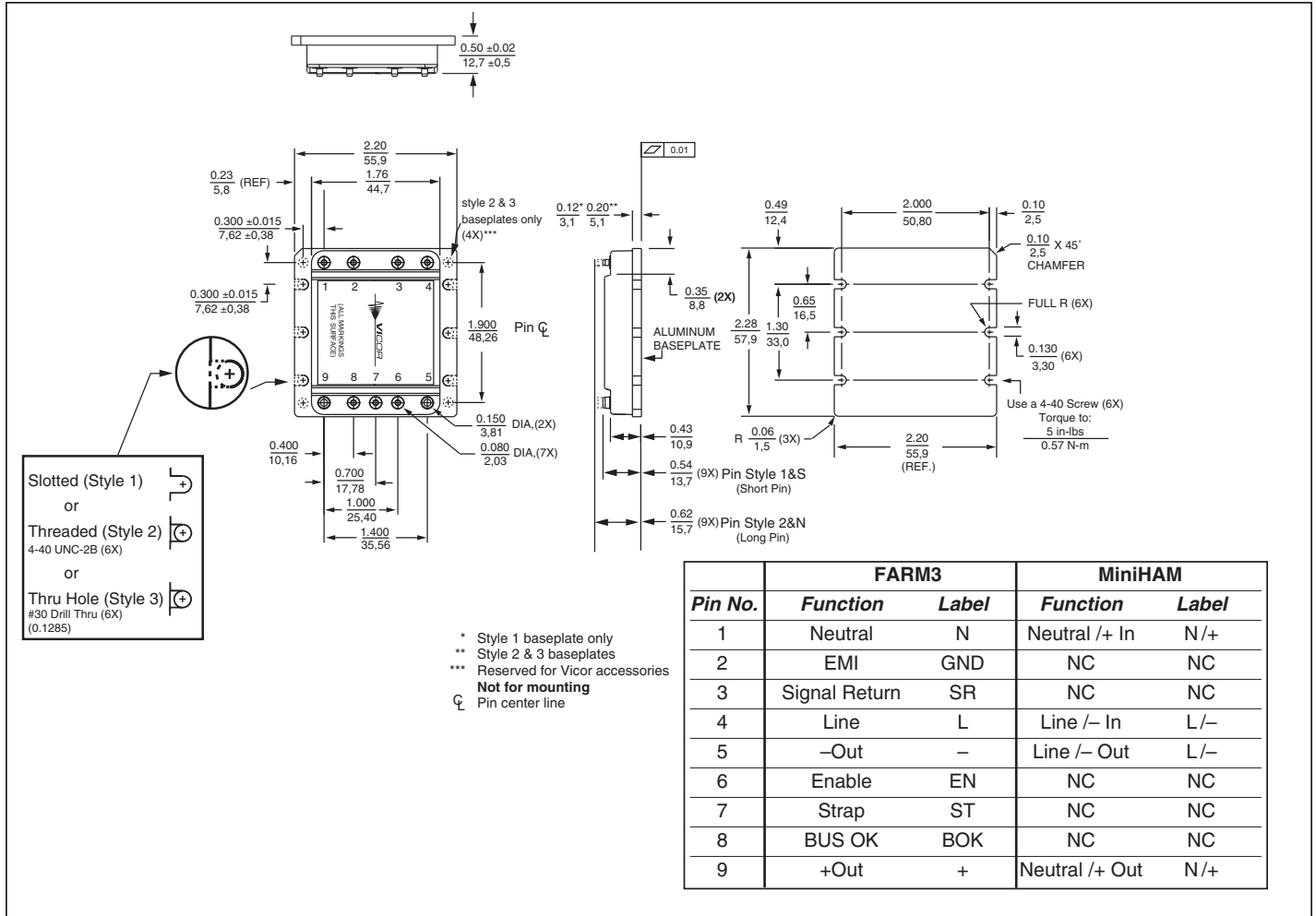

Figure 18a — Mechanical Diagram

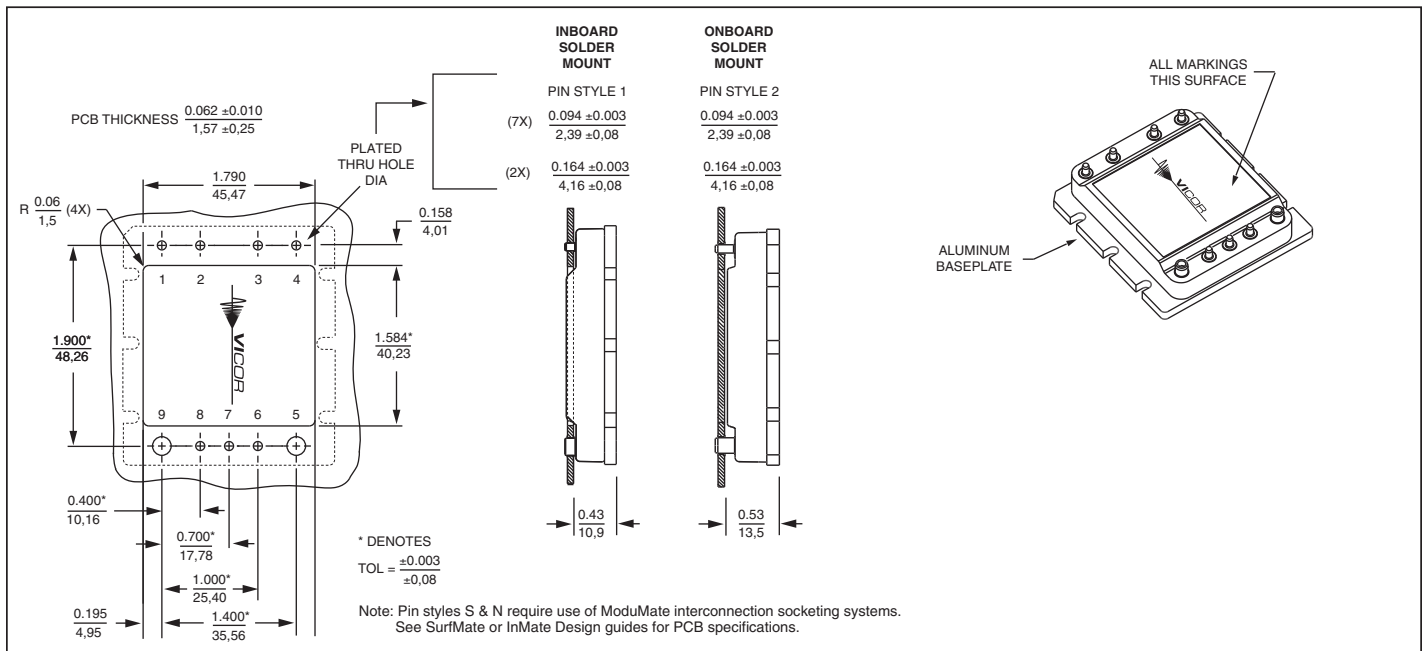

Figure 18b — PCB Mounting Specifications

Warranty

Vicor products are guaranteed for two years from date of shipment against defects in material or workmanship when in normal use and service. This warranty does not extend to products subjected to misuse, accident, or improper application or maintenance. Vicor shall not be liable for collateral or consequential damage. This warranty is extended to the original purchaser only.

EXCEPT FOR THE FOREGOING EXPRESS WARRANTY, VICOR MAKES NO WARRANTY, EXPRESS OR IMPLIED, INCLUDING, BUT NOT LIMITED TO, THE WARRANTY OF MERCHANTABILITY OR FITNESS FOR A PARTICULAR PURPOSE.

Vicor will repair or replace defective products in accordance with its own best judgement. For service under this warranty, the buyer must contact Vicor to obtain a Return Material Authorization (RMA) number and shipping instructions. Products returned without prior authorization will be returned to the buyer. The buyer will pay all charges incurred in returning the product to the factory. Vicor will pay all reshipment charges if the product was defective within the terms of this warranty.

Information published by Vicor has been carefully checked and is believed to be accurate; however, no responsibility is assumed for inaccuracies. Vicor reserves the right to make changes to any products without further notice to improve reliability, function, or design. Vicor does not assume any liability arising out of the application or use of any product or circuit; neither does it convey any license under its patent rights nor the rights of others. Vicor general policy does not recommend the use of its components in life support applications wherein a failure or malfunction may directly threaten life or injury. Per Vicor Terms and Conditions of Sale, the user of Vicor components in life support applications assumes all risks of such use and indemnifies Vicor against all damages.

Vicor's comprehensive line of power solutions includes high density AC-DC and DC-DC modules and accessory components, fully configurable AC-DC and DC-DC power supplies, and complete custom power systems.

Information furnished by Vicor is believed to be accurate and reliable. However, no responsibility is assumed by Vicor for its use. Vicor components are not designed to be used in applications, such as life support systems, wherein a failure or malfunction could result in injury or death. All sales are subject to Vicor's Terms and Conditions of Sale, which are available upon request.

Specifications are subject to change without notice.

Intellectual Property Notice

Vicor and its subsidiaries own Intellectual Property (including issued U.S. and Foreign Patents and pending patent applications) relating to the products described in this data sheet. Interested parties should contact Vicor's Intellectual Property Department.

Vicor Corporation
25 Frontage Road
Andover, MA, USA 01810
Tel: 800-735-6200
Fax: 978-475-6715

email

Customer Service: custserv@vicorpower.com
Technical Support: apps@vicorpower.com